

# Pulse

Installation instructions



**Table of contents**

<b>TABLE OF CONTENTS</b>	<b>2</b>
<b>MODELS AND CHARACTERISTICS</b>	<b>3</b>
<b>ACCESSORIES</b>	<b>3</b>
<b>CERTIFICATIONS</b>	<b>4</b>
<b>IMPORTANT NOTES!</b>	<b>4</b>
<b>KEYPAD DIMENSIONS</b>	<b>6</b>
<b>SWINGBOLT LOCK DIMENSIONS</b>	<b>6</b>
<b>DEADBOLT LOCK DIMENSIONS</b>	<b>7</b>
<b>LATCHBOLT LOCK DIMENSIONS</b>	<b>7</b>
<b>MOTORLOCK LOCK DIMENSIONS</b>	<b>7</b>
<b>MOTOR LATCHBOLT LOCK DIMENSIONS</b>	<b>8</b>
<b>KEYPAD ROTATING KIT INSTALLATION INSTRUCTIONS (ACCESSORY, P.N. T3300)</b>	<b>8</b>
<b>FIXED KEYPAD INSTALLATION INSTRUCTIONS</b>	<b>9</b>
<b>SWINGBOLT LOCK INSTALLATION INSTRUCTIONS</b>	<b>10</b>
<b>DEADBOLT AND LATCHBOLT LOCKS INSTALLATION INSTRUCTIONS</b>	<b>11</b>
<b>MOTORLOCK AND MOTOR LATCHBOLT LOCKS INSTALLATION INSTRUCTIONS</b>	<b>12</b>
<b>BATTERY REPLACEMENT PROCEDURE</b>	<b>14</b>
<b>FUNCTIONAL TEST</b>	<b>14</b>
<b>CORRECT DISPOSAL OF THIS PRODUCT:</b>	<b>20</b>
<b>(WASTE ELECTRICAL &amp; ELECTRONIC EQUIPMENT)</b>	<b>20</b>
<b>CONTACTS</b>	<b>20</b>

# Pulse

## Models and characteristics

Model	Variant
<b>T6430/B/BR</b> – Pulse keypad in ABS. Black colour. Black rubber membrane foil keypad.	
<b>T6530</b> – Pulse in metal. Satin chrome colour	<b>/B</b> Black color.
	<b>/GR</b> with rubber membrane foil keypad in grey color.
	<b>/BR</b> with rubber membrane foil keypad in black color.
	<b>/DL</b> with Dallas key reader.
	<b>/LH</b> lighted keypad.

## Accessories

Code	Description
<b>T3300</b>	Rotating back plate kit.
<b>NL1000</b>	Mounting adapter.
<b>T20019/T, T20016/T</b>	* Cabling interface/Adapter.
<b>L4001</b>	* Large battery box for 6 size C 1.5V batteries.
<b>T6006</b>	* Power supply interface 12÷24 Vdc with alarm interface.
<b>L2666</b>	* Knob with 6 mm square spindle. Spindle can be also provided as single piece (code PLT019, 10cm).
<b>N1982</b>	* User Dallas key.

(\*): not used for UL application

## Audit and programming accessories

Code	Description
N42180/T	* USB interface.
N42170/D	* Dallas key reader with molex connector.
N1996	* Audit and setup Dallas key.
(*) : not evaluated by UL	

## Certifications

The updated certifications are available on the official website of Tecnosicurezza:

[www.tecnosicurezza.it](http://www.tecnosicurezza.it)

## Important notes!

- The following procedure must be undertaken by a qualified competent. For any concerns about the safety of this product, please write to us on: [Contact Us | Tecnosicurezza](#)
- Before installing this product, please read carefully the installation and operating instructions.
- Locks can be installed in all traditional safes.
- Lock has to be mounted on secure storage metal (preferred steel) units only.
- Although locks can be mounted behind the passage hole for the connection cable or the spindle, it is instead recommended to install them on the door, but away from any through holes, in order to protect the locks themselves against external attacks.
- Any electronic part must be properly protected and not easily accessible even when the door is open.
- Locks have been developed to work correctly in a temperature range from -5 ° C to + 50 ° C and in an environment with non-condensing humidity between 25% and 90%.
- The mounting dimensions are standard (magic module).

## Pulse

- For the installation of the keypad and lock, use only the screws provided by Tecnosicurezza. Any other screw must be approved in advance.
- Locks are supplied with metric (M6) mounting screws. Upon request, Imperial 1/4-20 UNC format mounting screws are available.
- The type of material and the length of the screws must, in any case, be selected so as to guarantee long life and reliability.
- Tighten the screws so that the lock is firmly fixed to the mounting surface (recommended torque between 3 and 5 Nm).
- The mounting surface must be perfectly flat.
- In order to prevent loosening of the screws it is recommended the use of LOCTITE® threadlocker and/or specific washers positioned under the head of the fixing screw.
- The diameter of the passage hole for the connection cable or the spindle must not exceed 11 mm.
- The hole must be completely cleaned of drill dust and no edge should be sharp.
- Lock must not be lubricated.
- In the locked position, the distance between the bolt and the boltwork part that is moving the lock bolt must comply with the following specifications for each type of lock.
- Any component to be fixed to the lock bolt must be previously approved by Tecnosicurezza before installation. In any case, the maximum load must not exceed 4 N for T4710/M model and 30 N for T4710/MP reinforced model.
- Secure the cables away from moving parts by using cable ties and cable ties bases.
- If placed in normal domestic or office environments, the locks do not require particular maintenance; in any case, after 10,000 opening/locking cycles, it is recommended to run a test that verifies the correct and complete operation of the product.
- Use only DURACELL™ 9 Volt Alkaline batteries, or battery holders with DURACELL™ 1.5 Volt Alkaline batteries. Alternatively, it is also possible to use a stabilized power supply from 12 to 24 Vdc and 1A with relative power supply interface\* (p.n. T6006).
- **IMPORTANT:** if a power adapter is used, it must be compliant with national product directives and provided with short circuit protection.
- A series of acoustic signals during opening indicate a low battery level. In this case, the battery must be replaced.



# Pulse

## DeadBolt lock dimensions

T4700/D & T4710/D

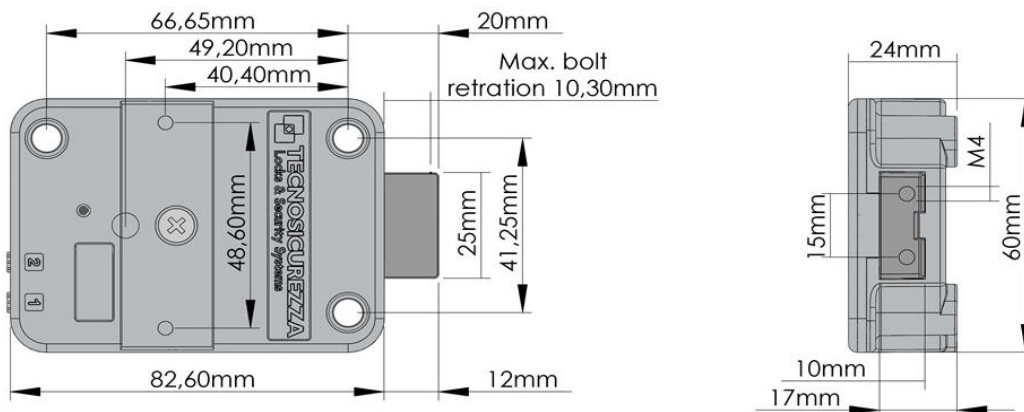

## LatchBolt lock dimensions

T4700/S & T4710/S

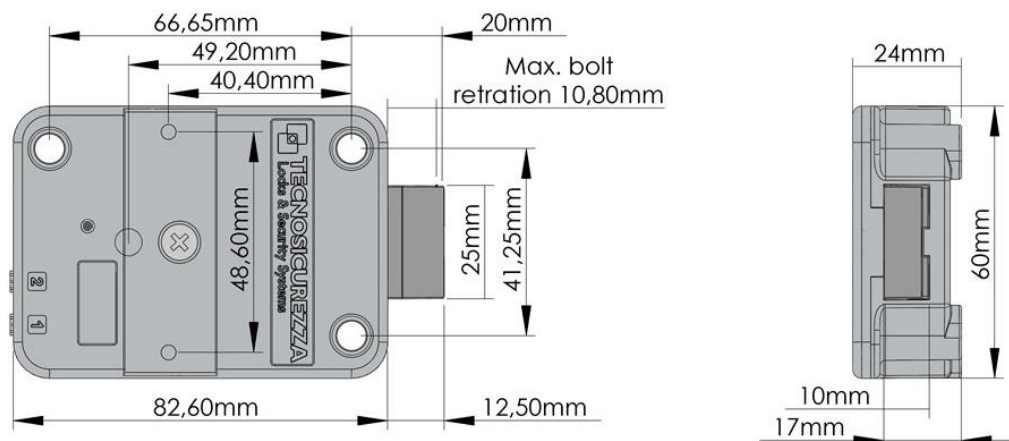

## MotorLock lock dimensions

T4710/M & T4710/MP

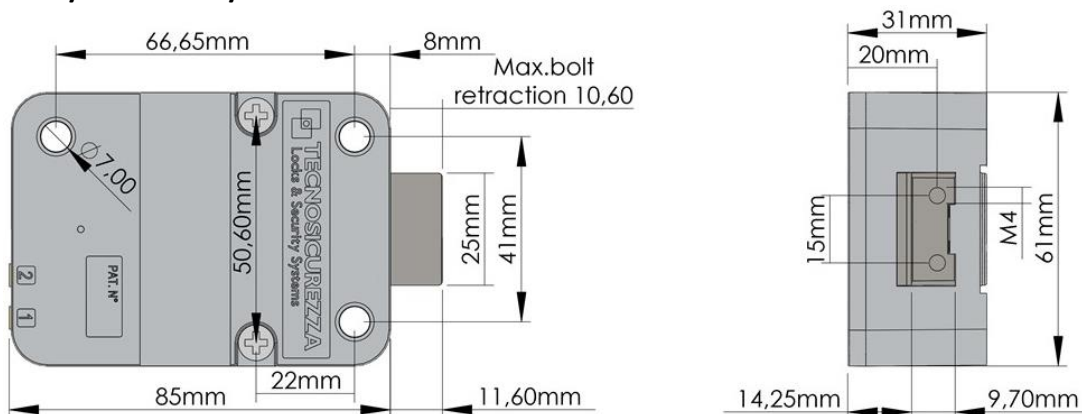

## Motor LatchBolt lock dimensions

### T4710/M/S

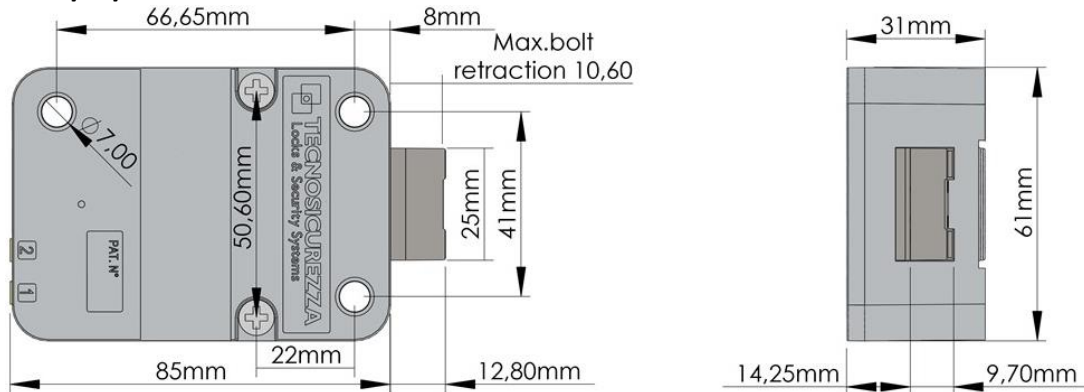

## Keypad rotating kit installation instructions (accessory, p.n. T3300)

**The rotation kit consists of 2 bushings, 2 M4 countersunk screws, 1 plastic pin, 1 spring and 1 rotating backplate.**

(Imperial screws 8-32 UNC are available on request.)

NOTE: use only the spindle provided by Tecnosicurezza. Any other spindle model must be previously approved by Tecnosicurezza before installation.

Cut the grooved shaft (spindle) to the appropriate length: measure door thickness (from mounting surface of the entry unit to the mounting surface of the lock) and add 26 mm (1"). Prepare the mounting and cable holes.

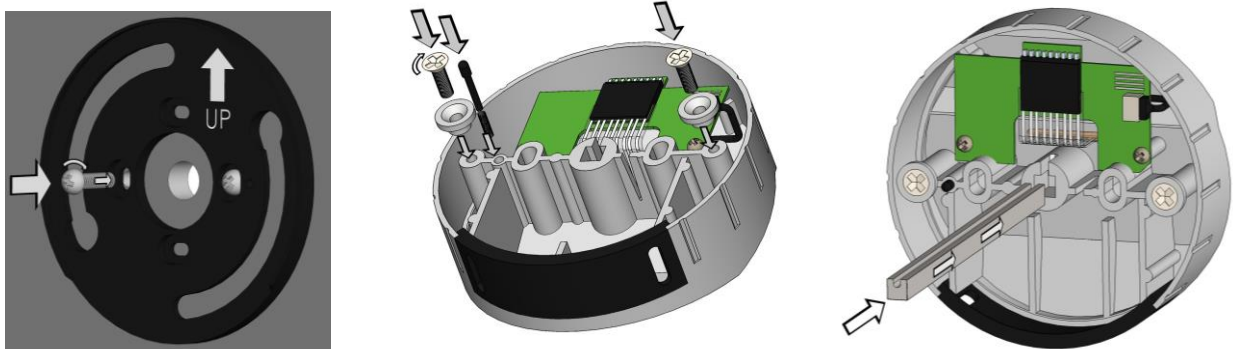

Fix the screws (M4) and the rotating backplate, positioning the latter on the side marked "UP".

Fix the bushings to the keypad housing using the supplied screws.

Insert the pin completely in the spring and then place it into the specific hole in the case.

Insert the grooved shaft, with the cutting edge first, all the way into the keypad housing.

## Pulse

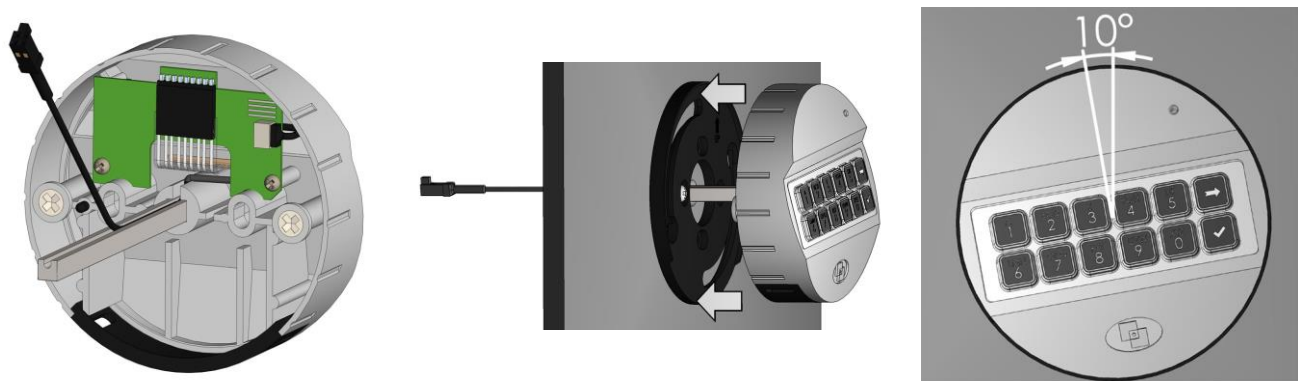

Place the connection cable inside the groove in the spindle.  
 Insert the cable and the spindle inside the spindle hole made in the door, keeping the keypad in angled position (10:00 o' clock) hook the keypad to the rotating backplate.  
 Then turn unit clockwise into position at 12:00 o' clock until you hear a click, reaching the final position.

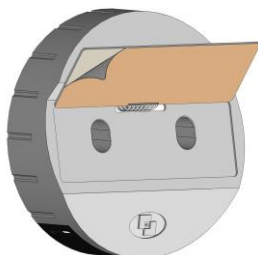

Remove the release liner placed under the membrane and apply the latter on the keypad case.  
 Connect a battery to the battery connector inside the keypad battery compartment or, if provided, connect the battery pack to the lock connector "2/BAT".

## Fixed keypad installation instructions

Insert the keypad cable inside the hole on the safe door and connect it to the lock connector "1/ENT".  
 Lift the keypad membrane and, making sure that the connection cable and the battery cable are not damaged by the keypad case, fix the screws to the relative threaded holes on the safe door.

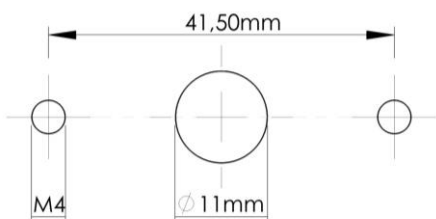

Remove the release liner placed under the membrane and apply the latter on the keypad case.  
 Connect a battery to the battery connector inside the keypad battery compartment or, if provided, connect the battery pack to the lock connector "2/BAT".

## SwingBolt lock installation instructions

The SwingBolt lock is a swinging bolt lock whose block is carried out by a motor; it can be installed in all 4 directions, even upside down.

By entering a valid code, the lock electronic removes the blocking for 3 seconds and the boltwork can be moved into open position by pushing the bolt inside the lock case.

The bolt automatically secures when the safe handle, or the safe door mechanism, is brought to the locked position.

If the SwingBolt lock is used in conjunction with other locks, the safe door mechanism must ensure the closure of the SwingBolt before the other locks.

The lock can be mounted in all four mounting directions (RH, LH, VU, VD).

Furthermore, by flipping over the lock, both locking directions can be realized.

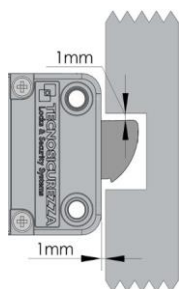

In the locked position the distance between the lock's bolt and the lock part that moves the bolt should be approximately 1 mm.

The bolt must be able to move freely without force being applied to it.

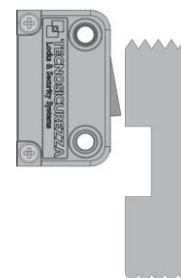

The maximum load applicable to the bolt must not exceed 1 KN. Contact Tecnosicurezza in case of heavier loads.

Connect the keypad cable to the lock connector "1/ENT", making sure it is fully inserted and locked.

Any alarm interface or battery holder needs to be connected to the lock connector "2/BAT".

To remove the cable, bring the connector upwards and carefully pull it out.

It's possible to connect a relocker to the lock cover through the appropriate holes.

Fix the relocker plate with M4 self tapping flat head screws. Length must be 6 mm + plate thickness.

(i.e. 6 mm + 2 mm plate = 8 mm screw)



# Pulse

## DeadBolt and LatchBolt locks installation instructions

DeadBolt and LatchBolt are locks with, respectively, a dead bolt and a spring bolt, whose block is carried out by a motor.

By entering a valid code, the lock electronic removes the blocking for 3 seconds and the boltwork can be moved into open position by turning the spindle inserted in the lock.

The spindle can be connected to a knob, a handle or directly to the keypad if equipped with a rotation kit. In the latter case it must be used the specific rotation kit T3300. When the spindle is brought to the locked position, the bolt comes out ensuring the lock is locked.

NOTE: use only the spindle provided by Tecnosicurezza. Any other spindle model must be previously approved by Tecnosicurezza before installation.

The DeadBolt and LatchBolt locks can be mounted in all four mounting directions (RH, LH, VU, VD).

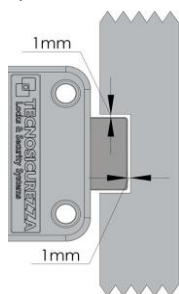

In the locked position, there should be approximately 1 mm clearance between the lock bolt and the cavity in the blocking bar of the boltwork. The bolt must be able to move freely without force being applied to it.

In open position, there should be a minimum of 3mm and maximum of 5 mm clearance between the lock bolt and the blocking bar of the boltwork.

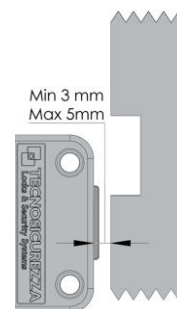

The maximum load applicable to the bolt must not exceed 1KN. Contact Tecnosicurezza in case of heavier loads.

The LatchBolt lock is specially designed to ensure self locking when the door closes.

### T4700/S & T4710/S

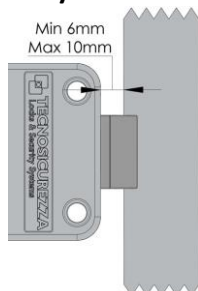

The distance between the LatchBolt lock and the locking edge must be between a minimum of 6 mm and a maximum of 10 mm.

When locked, there must be a 0.5 mm gap between lock bolt and locking surface.

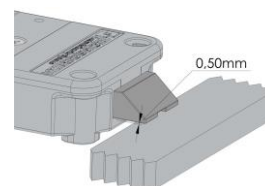

Cut the spindle to the correct length (measure door thickness + mounting plate/rotation knob or handle insert + lock spindle insert).

Remove any cutting residues of the spindle that could damage the cable.

### T4700/D & T4710/D locks

The spindle needs to be fully inserted inside the lock (7 mm).

Place the cable in the groove of the spindle, making sure it's fully inserted and locked.

Secure the cable inside the special groove located under the lock body, ensuring that it is not stretched when turning the spindle.  
Fix the lock using the appropriate mounting screws.

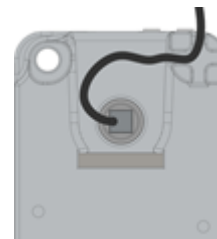

Connect the keypad cable to the lock connector "1", making sure it is fully inserted and locked. Any alarm interface or battery holder needs to be connected to the lock connector "2". To remove the cable, bring the connector upwards and carefully pull it out.

It's possible to connect a relocker to the lock cover through the appropriate holes.

Fix the relocker plate with M4 self tapping flat head screws.  
Length must be 6mm + plate thickness.

(i.e. 6 mm + 2 mm plate = 8 mm screw)



## MotorLock and Motor LatchBolt locks installation instructions

MotorLock and Motor LatchBolt locks are locks with, respectively, a motor driven dead bolt and a motor driven spring bolt, whose block is carried out by a motor.

By entering a valid code, the motor retracts the bolt which remains in the open position for about 8 seconds (unless differently programmed) before returning in closing position and the keypad beeps twice to confirm the bolt secure blocking.

If the manual relocking option is selected, the bolt closes by pressing any button.

Both lock versions can be mounted in all four mounting directions (RH, LH, VU, VD).

Locks is supplied with metric (M6) mounting screws. Upon request, Imperial 1/4-20 UNC format mounting screws are available.

# Pulse

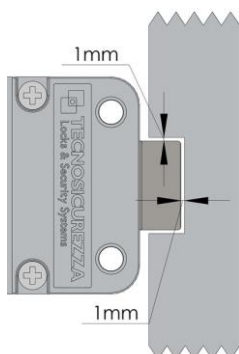

In the locked position, there should be approximately 1 mm clearance between the lock bolt and the cavity in the blocking bar of the boltwork. The bolt must be able to move freely without applying any force on it.

In open position, there should be a minimum of 3 mm and maximum of 5 mm clearance between the lock bolt and the blocking bar of the boltwork.

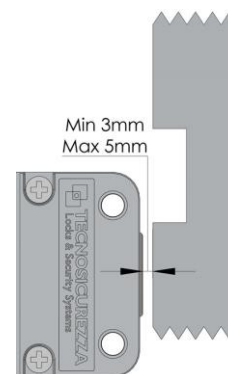

The Motor LatchBolt lock is specially designed to ensure self locking when the door closes.

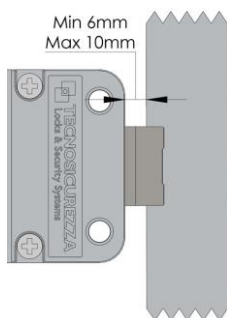

The distance between the lock and the locking edge must be between a minimum of 6 mm and a maximum of 10 mm.

When locked, there must be a 0.5 mm gap between lock bolt and locking surface.

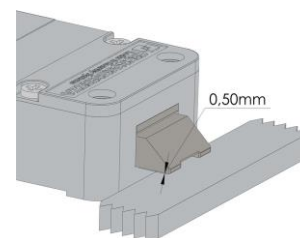

Connect the keypad cable to the lock connector "1", making sure it is fully inserted and locked.

Any alarm interface or battery holder needs to be connected to the lock connector "2".

To remove the cable, bring the connector upwards and carefully pull it out.

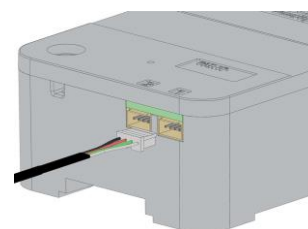

The Push & Pull version\* (T4710/MP) is supplied by default with RCS option, where closing is triggered by an external signal (i.e. boltwork switch) and the keypad beeps twice to confirm the bolt secure blocking. This avoids the motor to be activated when boltworks are not expanded yet. It's recommended to correctly use this signal to avoid motor damages.

## Installation instructions

### Pulse

Lock is also programmed by default with 8 seconds automatic reclosure, which can be modified upon request. This means that if the lock will open but the external signal don't (i.e. boltworks not expanded), lock will automatically close after 8 seconds (smart reclosure).

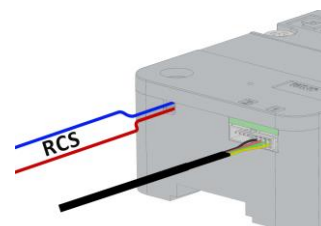

The maximum load applicable to the bolt must not exceed the limit values specified in the table below. Contact Tecnosicurezza in case of heavier loads.

Lock reference	Lock version	Maximum force to apply on the bolt	Maximum load pulled up and pushed by the bolt
T4710/M	Pull and spring version – Cass B	1KN (100 Kg)	4 N (400 gr)
T4710/MP	Push and pull version – Class B	1KN (100 Kg)	30 N (3Kg)
T4710/M/S	Latch version	1KN (100 Kg)	-

It's possible to connect a relocker to the lock cover through the appropriate holes.

Fix the relocker plate with M4 self tapping flat head screws.  
Length must be 6mm + plate thickness.

(i.e. 6 mm + 2 mm plate = 8 mm screw)



## Battery replacement procedure

It is recommended to perform this operation always with the door open.

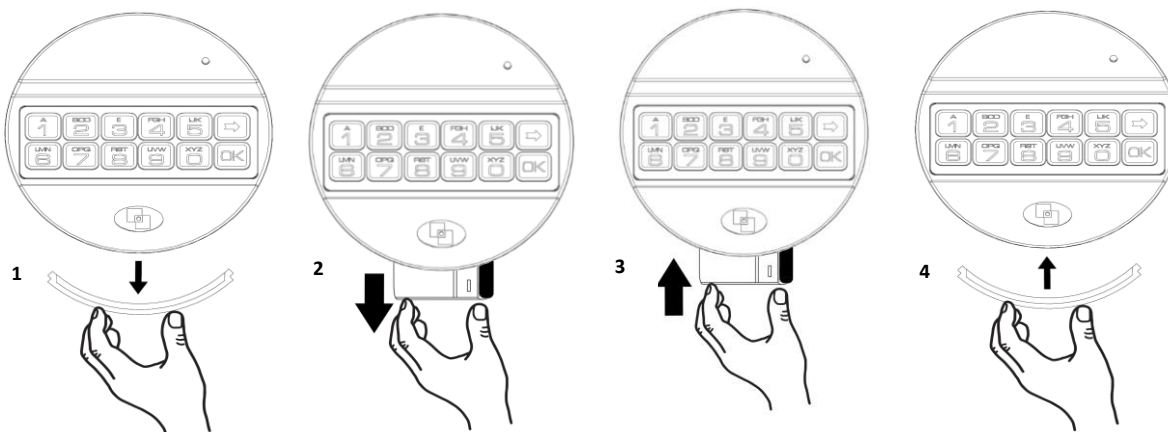

## Functional test

To be carried out with the door open.

## Pulse

### *MEMBRANE TEST:*

Press and hold button 5 until the double beep (the LED will remain on).

Slowly enter all the buttons according to the sequence below:

[1]-[2]-[3]-[4]-[5]-[6]-[7]-[8]-[9]-[0]

A double beep after pressing each single button indicates that the keypad correctly communicates with the lock.

A long beep indicates an electronic problem (in this case please contact the technical assistance).

### *ELECTRONIC / MECHANICAL TEST:*

#### *OPENING:*

Enter the opening code (standard code 123456 or simply 1 if the lock is in pre-setup mode).

The keypad produces a double beep. A long beep is produced instead, in case of incorrect code.

With SwingBolt and MotorLock locks, turn the safe door handle to the open position.

With DeadBolt and LatchBolt locks, rotate the knob or the keypad according to the type of installation and move the lock bolt to the open position.

For all types of locks the bolt must be able to move freely.

#### *KEYS ILLUMINATION:*

After powering the lock system or after pressing ☀, the keys illumination switches ON for about 10s.

#### *LOCKING:*

With SwingBolt and MotorLock locks, turn the safe door handle to the locked position. Lock bolt must fully extend and ensure locking (for MotorLock locks the keypad beeps twice to confirm the secure bolt locking).

With MotorLock and Motor LatchBolt locks with manual reclosure, turn the door handle towards the locked position and press any key. Lock bolt must fully extend and ensure locking. The keypad beeps twice to confirm the secure bolt locking.

With MotorLock Push & Pull locks, turn the door handle towards the locked position. Lock bolt must fully extend and ensure secure locking (the keypad beeps twice as confirmation). In this last case, the bolt can also be securely closed by pressing any key for few seconds in case of door/handle status detectors failure.

With DeadBolt locks, rotate the knob or the keypad according to the type of installation and move the lock bolt to the closing position.

With LatchBolt locks, push the door to close.

Even in these last two cases, lock bolt must fully extend and ensure locking.

#### **IMPORTANT**

For all locks without manual reclosure, after reclosing ensure that the door handle cannot be turned towards the open position (handle locked), in order to confirm the secure locking of lock bolt.

Make sure that there is free space in all directions around the bolt when the movement is brought to the locked position.

**Repeat the functional test several times before locking the safe door.**

**Failure to follow these installation instructions or opening the lock by personnel not authorized by Tecnosicurezza will void the warranty.**

## NOTES

---

---

---







**Correct disposal of this product:**

**(Waste Electrical & Electronic Equipment)**

Applicable in the European Union and other European countries with separate collection systems.



This marking displayed on the product or its literature indicates that it should not be disposed with other wastes at the end of its working life.

To prevent possible harm to the environment or human health from uncontrolled waste disposal, please separate this from other types of wastes and recycle it responsibly to promote the sustainable reuse of material resources.

## Contacts

### GLOBAL HEADQUARTERS

#### Tecnosicurezza Spa

Via Cesare Battisti, 276  
37057 San Giovanni Lupatoto  
Verona  
Tel.+39 045 826 64 70  
Fax. +39 045 826 64 69  
[info@tecnosicurezza.it](mailto:info@tecnosicurezza.it)  
[service@tecnosicurezza.it](mailto:service@tecnosicurezza.it)  
[infotecnosicurezza@pec.it](mailto:infotecnosicurezza@pec.it)

### USA HEADQUARTERS

#### Tecnosicurezza Inc.

133, Trade Street- Suite 4  
Lexington, KY 40511  
Tel.+1 859 682 50 25  
[info.usa@tecnosicurezza.it](mailto:info.usa@tecnosicurezza.it)

### SPAIN HEADQUARTERS

#### Tecnosicurezza Sa

C/Menor, 4 - Nave 10  
Pol. Ind La Mina  
28770 Colmenar Viejo  
SPAIN  
Tel.+34 91 804 33 91  
Fax.+34 91 804 32 63

[info.es@tecnosicurezza.it](mailto:info.es@tecnosicurezza.it)